

# Jumbo AR 1000

## 740-0025-12 Position 1

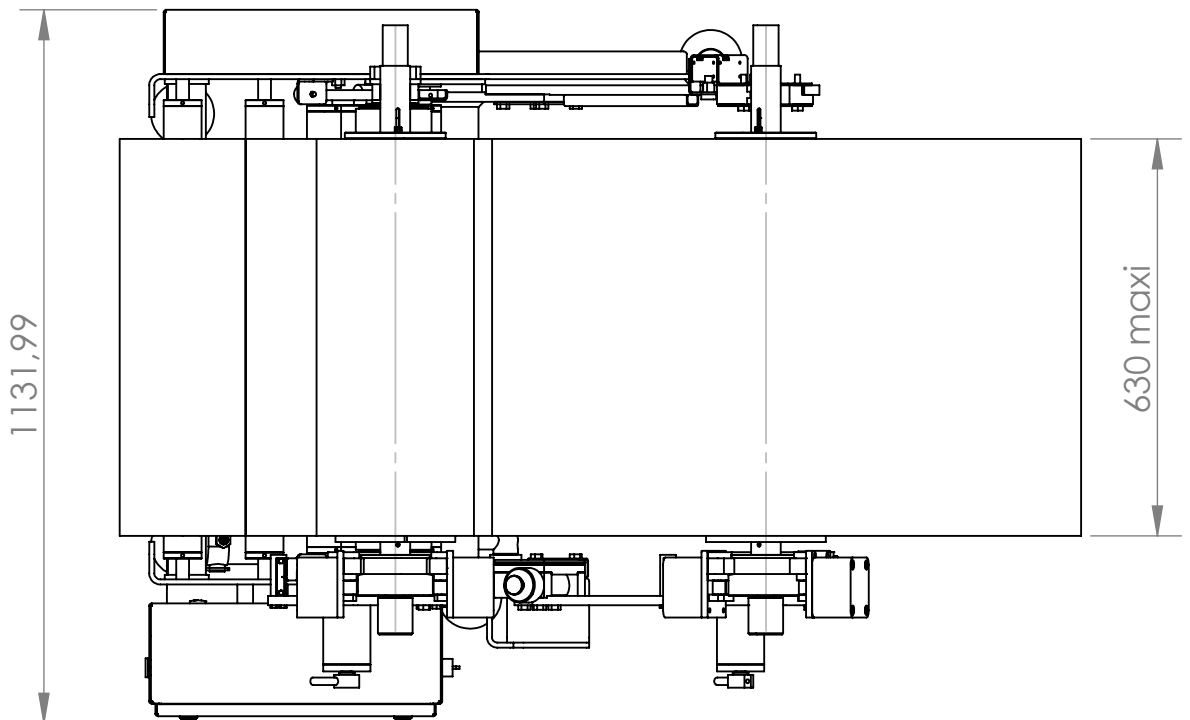
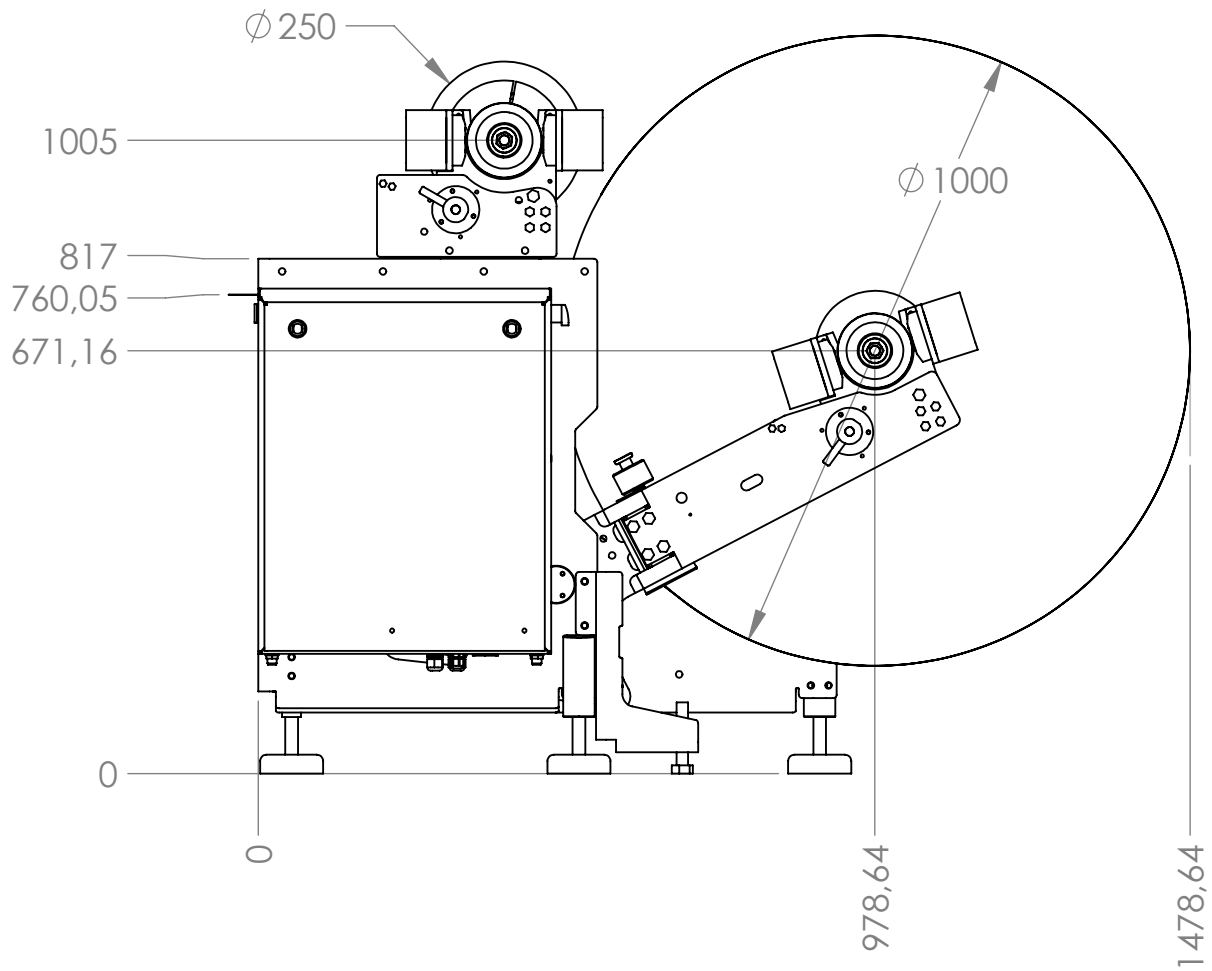

# Jumbo AR 1000

## 740-0025-12 Position 1 A

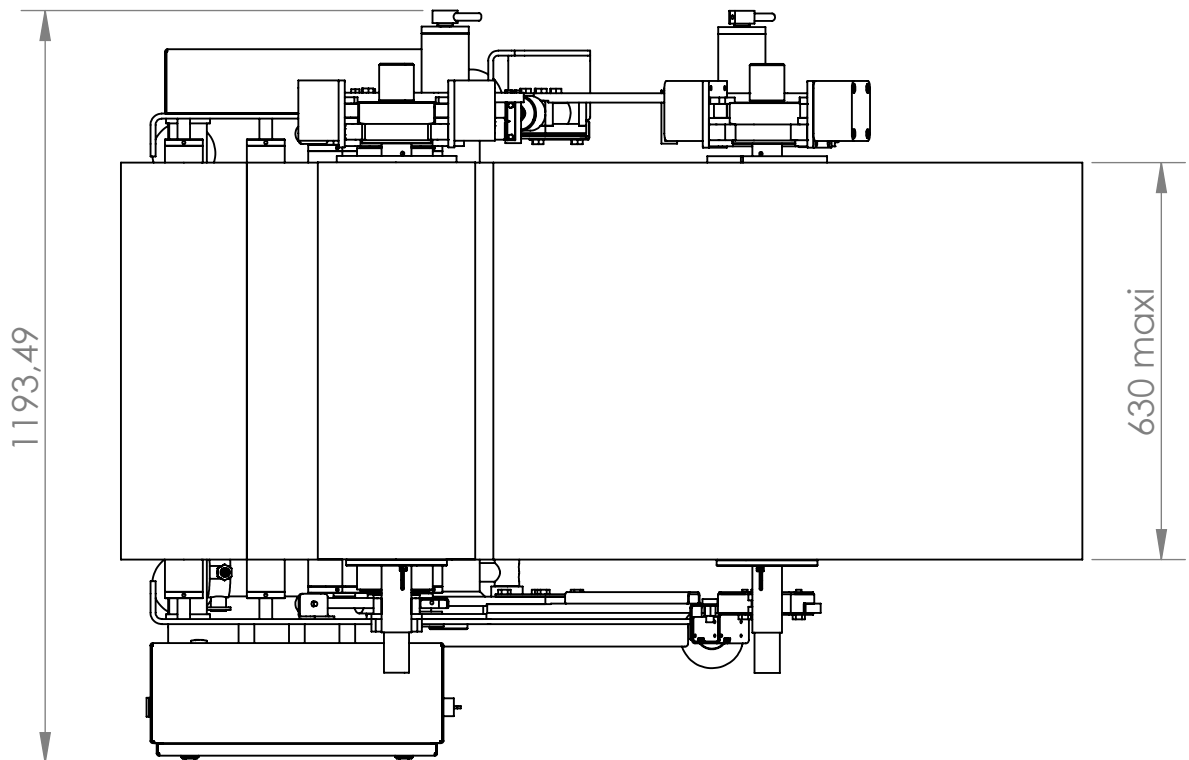
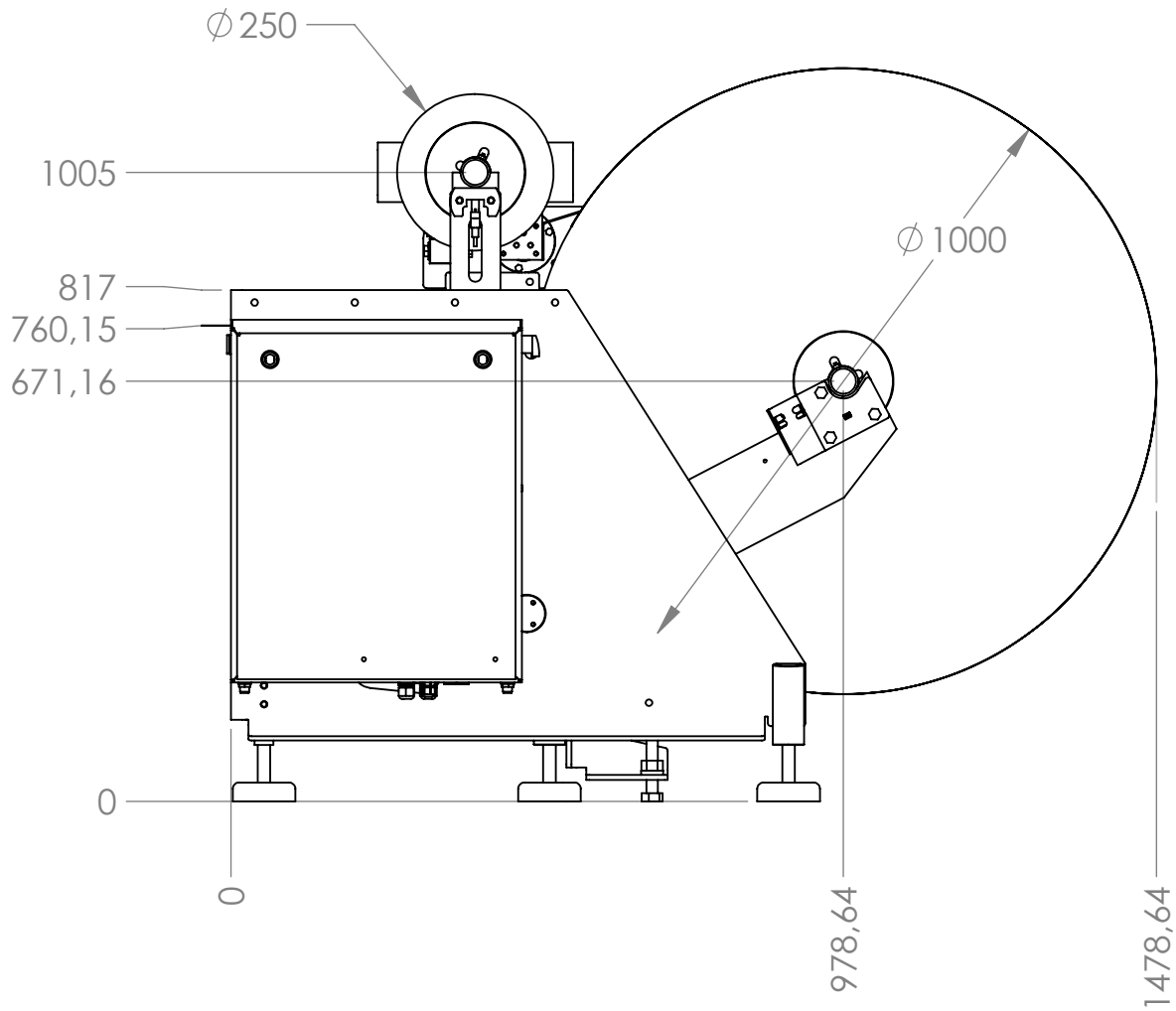

2019-2305-3-JFC

# Jumbo AR 1000

## 740-0025-12 Position 2

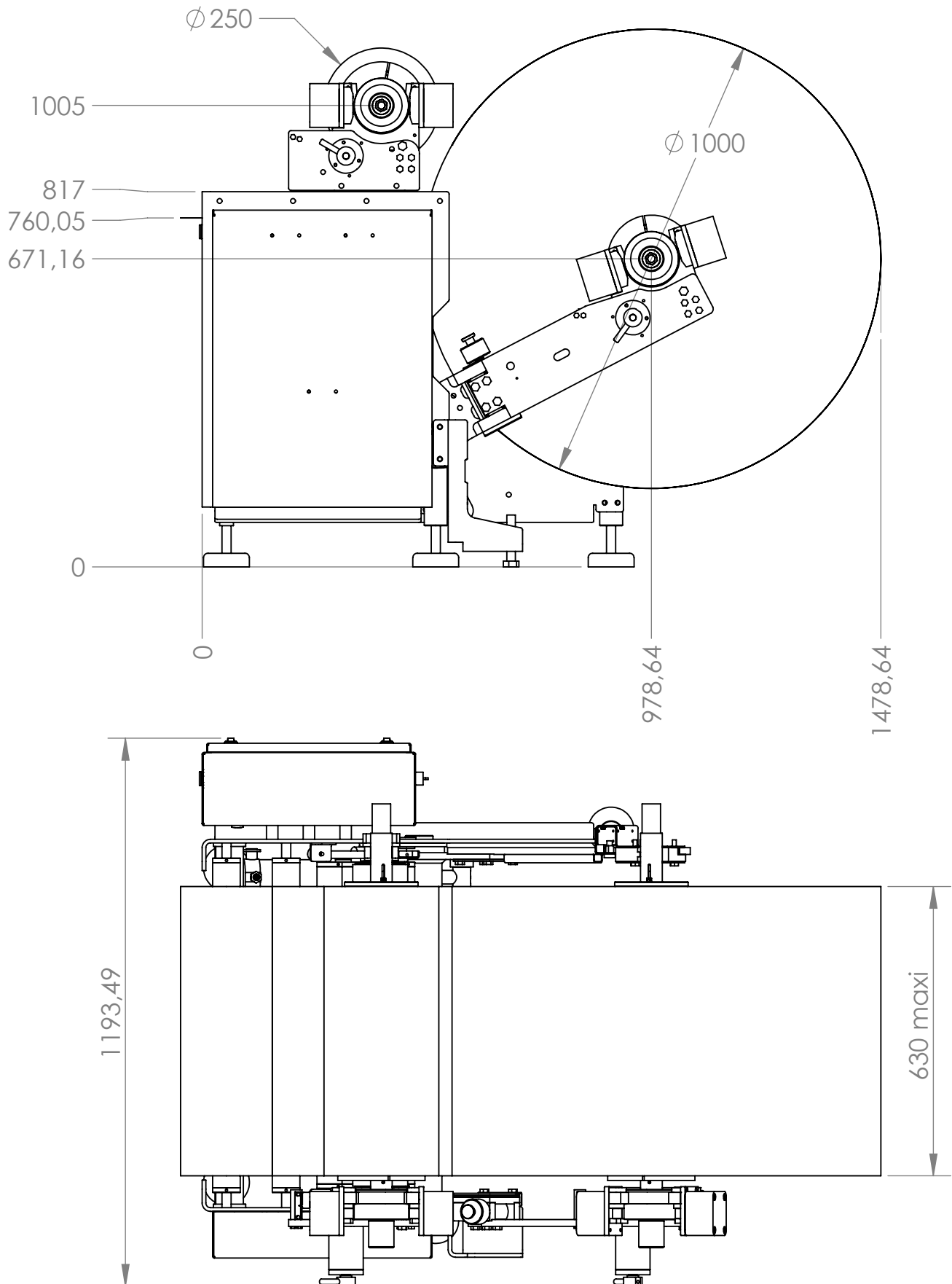

2019-2305-2-JFC

# Jumbo AR 1000

## 740-0025-12 Position 2 A

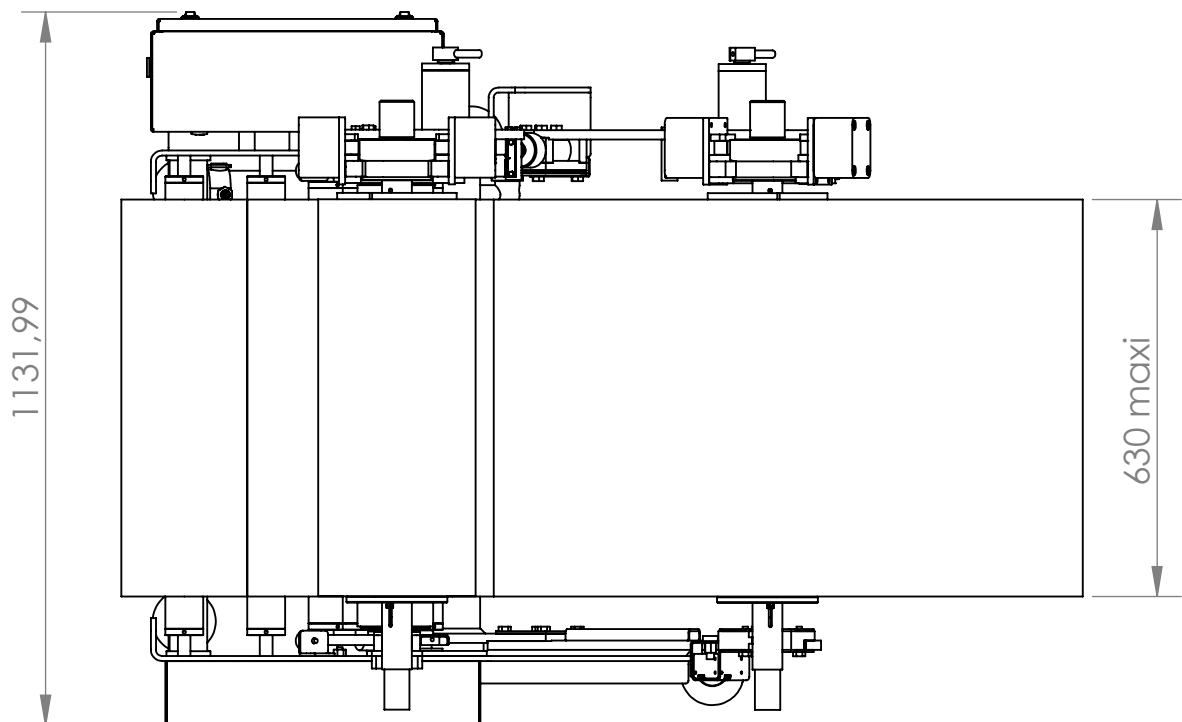
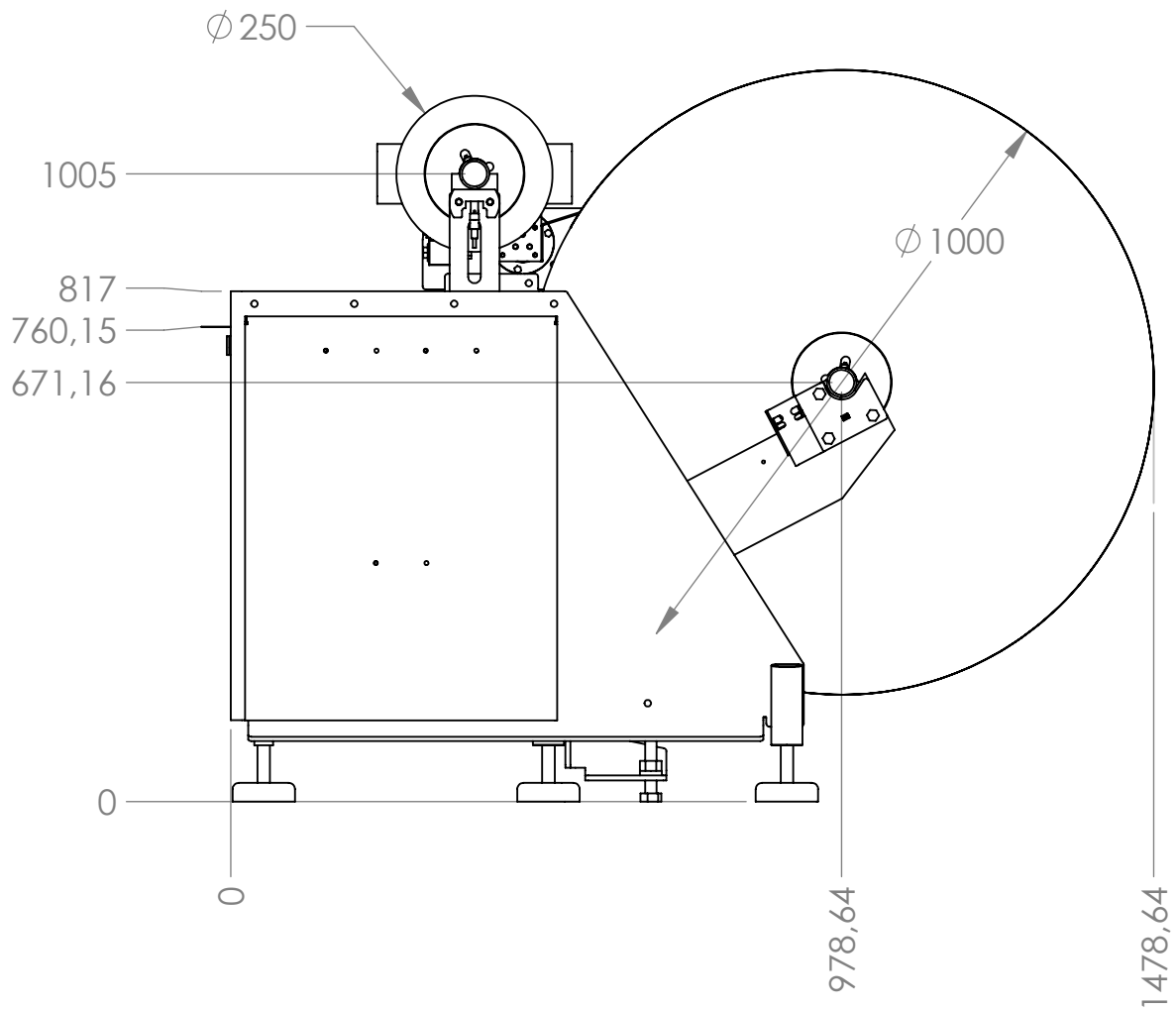

2019-2305-4-JFC

**JUMBO AR P1**  
**740-0025-12 P1**

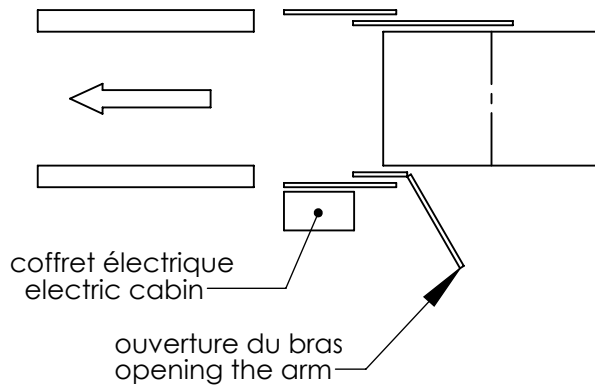

**JUMBO AR P1A**  
**740-0025-12 P1A**

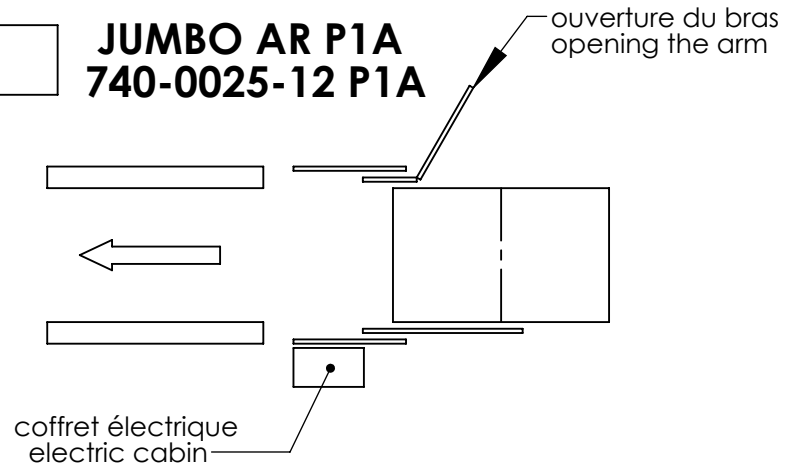

**JUMBO AR P2**  
**740-0025-12 P2**

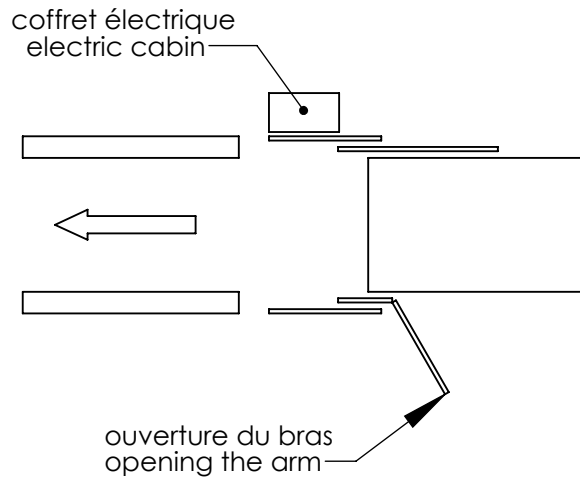

**JUMBO AR P2A**  
**740-0025-12 P2A**

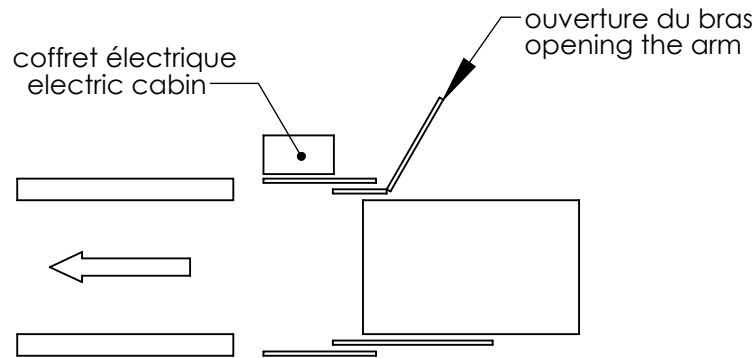

Client :  
Customer

Date :

Ø bobine (mm) =  
reel diameter

épaisseur film (mm) =  
film thickness

pas d'avance (mm) =  
advance step

cadence (coup/mn) =  
speed

tension (V) =  
power

laize (mm) =  
width

bague (3" ou 6") =  
ring (3" or 6")

langue doc. =  
language doc.

Jumbo AR/Jumbo Rear

**ADDITIF SYSTEME**

4 rue de Monnières 39100 Fouchérans

**2019-2309-JFC**